



Model FEC120



FEC120 Shelves



FEC120 Control Panel



SMARTSMOKER® FAST EDDY'S BY COOKSHACK COOKSHACK MENU CONSULTATION ON Q NEWSLETTER SPICE BLENDS & RUBS SMOKING WOODS BARBECUE SAUCES



2304 North Ash Street
Ponca City, OK
74601-1100 USA

Sales:
1.800.423.0698

Corporate Office:
580.765.3669

Fax:
580.765.2223

E-mail:
sales@cookshack.com

Web site:
www.cookshack.com



The Fast Eddy's by Cookshack FEC120 smoker is a 100% wood-burning, pellet-fired smoker with a Cookshack IQ4 electronic control system. Combining the features of the FEC100 that has made it the most popular manufactured pit on the cook-off circuit, with the offset firebox of the Fast Eddy's by Cookshack rotisserie units makes the FEC120 the perfect choice for restaurants, caterers, and competition cooks. It is NSF and USDA approved, and Warnock Hersey and ETL Listed Commercial Cooking Equipment.

FEC120 Features

- ❖ Capacity is 150 lbs. pork butts, 120 lbs. brisket, 90 lbs. ribs, and 30 chickens per load.
- ❖ The FEC120 features a digital Cookshack IQ4 controller. Operator sets the smoke-cooking time and temperature, and the holding temperature. When the smoke-cook cycle has finished, the controller drops automatically to the hold temperature. Optional meat probe allows user to specify a desired internal meat temperature. When the temperature is reached, the smoker automatically drops into a hold cycle.
- ❖ Electronically-controlled temperature eliminates large heat fluctuations that dry and shrink meat.
- ❖ The FEC's heat and flavor source is 100% food grade wood pellets. Pellets are easily obtainable, inexpensive, and easy to store; available in a variety of flavors.
- ❖ Pellet heat is controlled by a fully automatic wood pellet feed system for consistent heat and flavor.
- ❖ With continuous use, the FEC120 produces about 8 oz. of ash per 40 lbs. of pellets used. Danger of a fire from removing hot ash and embers is eliminated, unlike log burners that require removal of live coals.
- ❖ Clean-burning wood pellets produce very little ash, with low creosote buildup.
- ❖ The FEC120 runs at 7 amps @ 120 VAC.
- ❖ The FEC120 features double-walled construction surrounding 850° F Spin-Glas® insulation for superior heat retention and fuel savings.
- ❖ (5) nickel plated 23" X 17" shelves are removable . . . easy to wash.
- ❖ Standard equipment includes: cookbook, casters, operator's manual, 40 lbs. of pellets, and a Cookshack Spice Kit containing: 1 gal. Spicy Barbecue Sauce, 1 gal. Mild Barbecue Sauce, 5 lbs. Brisket Rub, 5 lbs. RibRub, 5 lbs. Spicy Chicken Rub, 10 oz. Chili Mix, and 10 oz. Spicy Barbecue Sauce Mix.
- ❖ No risk purchase . . . Fast Eddy's by Cookshack smokers are covered by a two-year limited warranty and Cookshack's 30-Day Money-Back Guarantee.
- ❖ Optional accessories include a meat probe, rib racks, stainless steel shelves, and a cover.



Model FEC120



2304 North Ash Street
Ponca City, OK
74601-1100 USA

Sales:
1.800.423.0698

Corporate Office:
580.765.3669

Fax:
580.765.2223

E-mail:
sales@cookshack.com

Web site:
www.cookshack.com



FEC120 Specifications

Food Capacity	15 square feet of cooking space: 150 lbs. pork butts, 120 lbs. brisket, 90 lbs, ribs, or 30 chickens per load
Electrical	7 amps @ 120 VAC; 36,000 BTU burner; electronically-controlled IQ4 thermostat; auto-start; draft fan
Shelves	(5) nickel plated steel 23" X 17" shelves spaced 5" apart
Outside Dimensions	46"W (54"W w/ firebox door open) x 57 1/4"H x 32"D
Hopper Capacity	20 lbs.
Fuel Consumption	.50 lbs. of pellets per hour at 250°F
Construction	Steel frame with double-walled stainless steel interior and exterior, 850° F Spin-Glas® insulation
Unit Weight	370 lbs.
Standard Equipment	Cookbook, operator's manual, 40 lbs. pellets, casters, and Cookshack Spice Kit containing: 1 gal. Spicy Barbecue Sauce, 1 gal. Mild Barbecue Sauce, 5 lbs. Brisket Rub, 5 lbs. RibRub, 5 lbs. Spicy Chicken Rub, 10 oz. Chili Mix, and 10 oz. Spicy Barbecue Sauce Mix
Approval / Listings	NSF and USDA approved, Warnock Hersey and ETL Listed Commercial Cooking Equipment
Warranty / Guarantee	2 year limited warranty and 30-Day Money-Back Guarantee

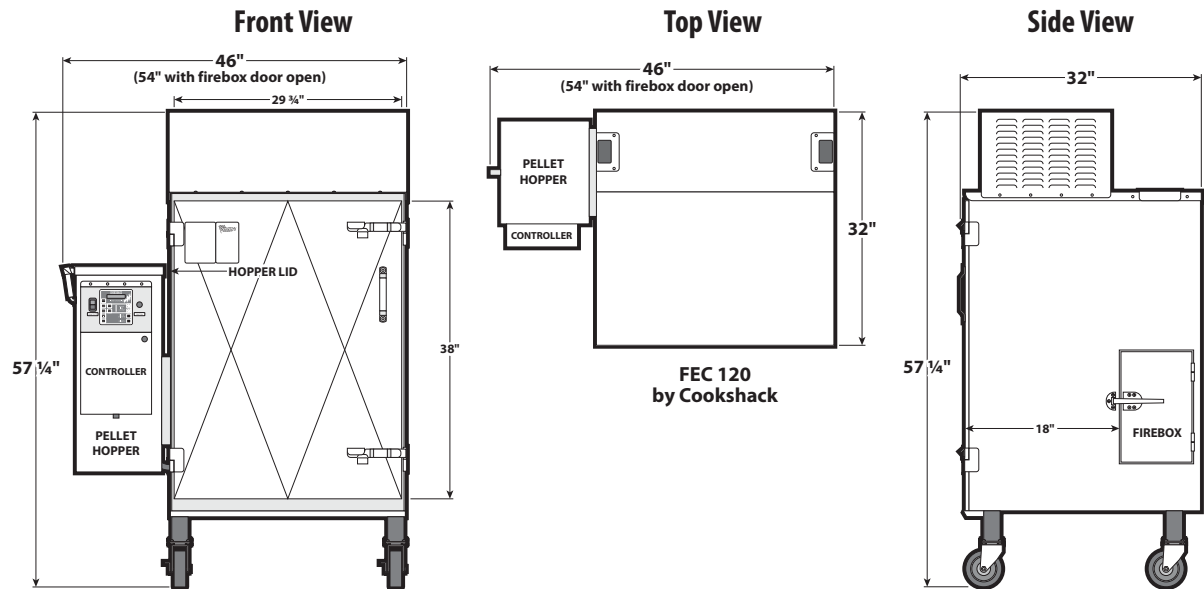

Pellet Specifications

Diameter	1/4"
Length	1/2" - 3/4"
Hardwood Content	100%
Density	40-46 lbs/cubic feet
Moisture Content	8%
Caloric Value	8,000 - 9,000 btu/lb
Ash Content	Less than 1%

About Pellets

Pellets are easily obtainable throughout the U.S. Cookshack supplies only 100% wood, food grade barbecue pellets specifically produced for use with food. Cookshack barbecue pellets are made from hardwoods that contain fewer resins and are produced in a controlled process to ensure a food grade product. (Heating pellets, on the other hand, are produced specifically for heat stoves and do not meet food grade requirements.) Barbecue pellets are made by pulverizing hardwood sawdust and extruding to a uniform density through a rotating die under enormous heat and pressure (400 degrees @ 10,000 PSI). Naturally occurring lignin in the wood binds the pellets into their shape. The pellets are then cooled and placed in 20 lb. bags.